

290 Series Tip 'N Pour

Model:
C29020-05,06,07,08
Optional Squeegee
Assy. 470100

OPERATION

SERVICE

PARTS

CARE

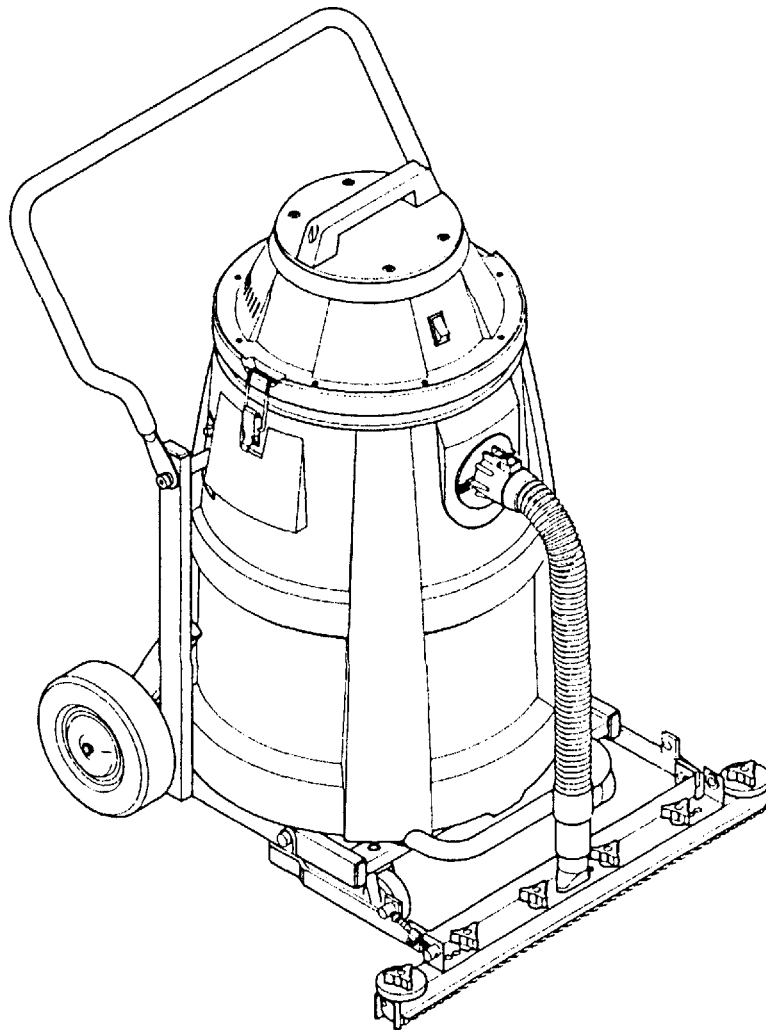

Revised 2/04

Minuteman[®]

FOR COMMERCIAL USE ONLY

IMPORTANT SAFETY INSTRUCTIONS

When using an electrical appliance, basic precautions should always be followed, including the following:

READ ALL INSTRUCTIONS BEFORE USING

WARNING - To reduce the risk of fire, electric shock, or injury:

- Do not leave appliance when plugged in. Unplug from outlet when not in use and before servicing.

WARNING

To reduce the risk of electric shock - Do not expose to rain. Store indoors.

- Do not allow to be used as a toy. Close attention is necessary when used by or near children.
- Use only as described in this manual. Use only manufacturer's recommended attachments.
- Do not use with damaged cord or plug. If appliance is not working as it should, has been dropped, damaged, left outdoors, or dropped into water, return it to a service center.
- Do not pull or carry by cord, use cord as a handle, close a door on cord, or pull cord around sharp edges or corners. Do not run appliance over cord. Keep cord away from heated surfaces.
- Do not unplug by pulling on cord. To unplug, grasp the plug, not the cord.
- Do not handle plug or appliance with wet hands.
- Do not put any object into openings. Do not use with any opening blocked; keep free of dust, lint, hair, and anything that may reduce air flow.
- Keep hair, loose clothing, fingers, and all parts of body away from openings and moving parts.
- Do not pick up anything that is burning or smoking, such as cigarettes, matches, or hot ashes.
- Do not use without dustbag and/or filters in place.
- Turn off all controls before unplugging.
- Use extra care when cleaning on stairs.
- Do not use to pick up flammable or combustible liquids such as gasoline or use in areas where they may be present.
- Connect to a properly grounded outlet only. See grounding instructions.

SAVE THESE INSTRUCTIONS

INSPECTION

Carefully unpack and inspect your machine for shipping damage. Each unit is tested and thoroughly inspected before shipment, and any damage is the responsibility of the delivery carrier who should be notified immediately.

ELECTRICAL - 115 Volt

This machine is designed to operate on a standard 15 amp, 115 volt, 60 hz, AC circuit. Voltages below 105 volts AC or above 125 volts AC could cause serious damage to the motor.

ELECTRICAL - 240 Volt

This machine is designed to operate on a standard 10 amp, 230 volt, 50 hz, AC circuit.

WARNING

Electric motors can cause explosions when operated near explosive materials or vapors. Do not operate this machine near flammable materials such as solvents, thinners, fuels, grain dust, etc.

GROUNDING INSTRUCTIONS

This appliance must be grounded. If it should malfunction or breakdown, grounding provides a path of least resistance for electric current to reduce the risk of electric shock. This appliance is equipped with a cord having an equipment-grounding conductor and grounding plug. The plug must be plugged into an appropriate outlet that is properly installed and grounded in accordance with all local codes and ordinances.

DANGER

Improper connection of the equipment-grounding conductor can result in a risk of electric shock. Check with a qualified electrician or service person if you are in doubt as to whether the outlet is properly grounded. Do not modify the plug provided with the appliance — if it will not fit the outlet, have a proper outlet installed by a qualified electrician.

This appliance is for use on a nominal 120-volt circuit and has a grounding plug that looks like the plug illustrated in sketch A below. Make sure that the appliance is connected to an outlet having the same configuration as the plug. No adapter should be used with this appliance.

Adapter not applicable in Canada.

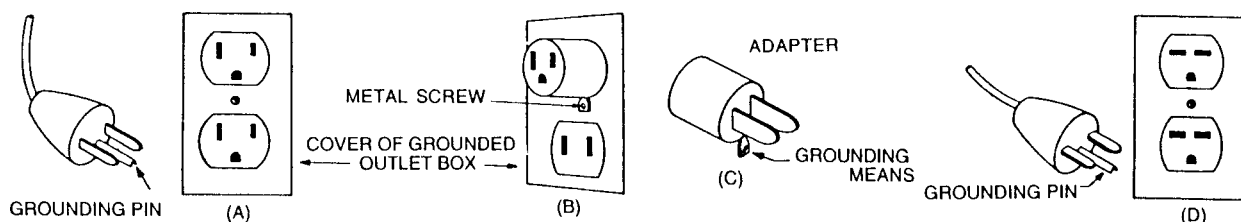

USER MAINTENANCE INSTRUCTIONS

All service and repair should be performed by qualified vacuum service representative or electrician. No user serviceable components are employed in the electrical vacuum lid head assembly. No lubrication of the motor is required.

CLOTH BAG & HOSE ASSY

Cloth bag and hose assy are user maintenance items and can be replaced when worn out. Cloth bags can be maintained by blowing dust off the bag and then laundered. Cloth bags should be completely dried before reinstalling into machine. For optimum performance, empty and clean filter bag regularly. A clogged and dirty bag restricts the flow of air and results in reduced vacuum. For liquid pickup, remove the dry dust filter bag. Check the automatic shut-off to be certain it is working properly. The hose assy can be maintained by wiping off with a dampened cloth of mild liquid soap and water, then allowed to dry.







CORD STORAGE

While not in use storage can be accomplished by winding cord around motor lid assy. Cord should be completely unwound from lid assy during operation.

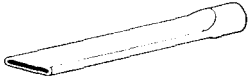
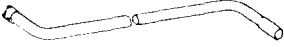
- Do not use with damaged cord or plug. If appliance is not working as it should, has been dropped, damaged, left outdoors, or dropped in water, return to service center.
- Do not pull or carry by cord, use cord as handle, close a door on cord, or pull cord around sharp edges or corners. Do not run appliance over cord. Keep cord away from heated surfaces.
- Do not unplug by pulling cord. To unplug, grasp the plug, not the cord.
- Do not handle plug or appliance with wet hands.

Always unplug the machine when removing the motor head off the tank. This equipment should be stored indoors and not exposed to rain.

TOOLS AND ACCESSORIES

		Part No.	Description
A		800083 133249 800084 808023	3" Rd. Dust Brush Complete Dust Brush HSG 3" Bristle Insert 3" Adapter
B		800035	12" Crev Tool Complete
C		290000 290001 290002	Wand Assy. 1-1/2, Complete Upper Wand Lower Wand
D		800317	Hose Assy. 1-1/2 x 10'
E		800603 800612 808648 803161 808592	14" Brush Tool Complete Brush Insert Tool Brush Clamp Bumper
F		800124 731	5" Tool Only Without Insert Bristle Insert Replacement
G		800605 712088 800615 808648 500295 500296	14" Squeegee, Complete SCR #10 HILO 14" Retaining Strip Nozzle, Squeegee Blade Squeegee Blade Squeegee Reinforcement
H		601032	11" Floor & Rug Tool

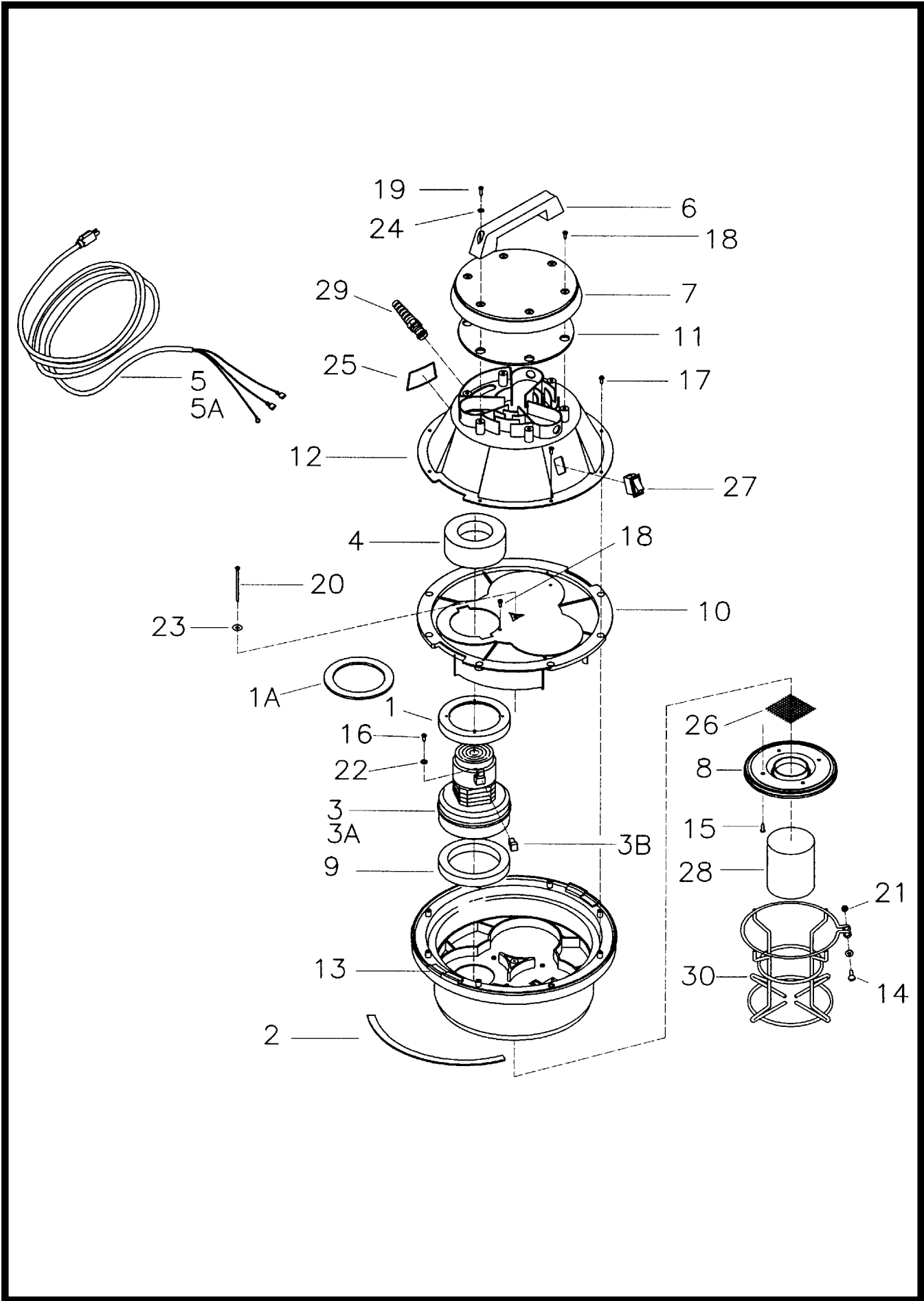

Parts Listings

Item	Part #	Qty	Description
1	290017	1	Molded Vac Moter Gasket
1A	380035	1	Gasket 4.31 x 5.81 x .19 (240V only)
2	290030	1	Lid Gasket Diecut 15G 290
3	380001	1	Vac Motor 6336-00 120V
3A	740149	1	Vac Motor 6296-13 240V
3B	380028	2	Carbon Brush Replacement
4	380064	1	Ring, Foam
5	381020	1	Cord-16GA-3 50FT Med Grey
5A	740600	1	Cord-European F3 G1.5MM Soft B
6	460000	1	Handle 460 Lid Black
7	460003	1	Lid Cover 460 Black
8	460011	1	Float Cage Adaptor 460 Black
9	460019	1	Gasket 3.75 x 5.75 x .75
10	460031	1	Motor Holddown 5.7 x 1
11	460045	1	Dome Seal Gasket 290
12	460070	1	Motor Cover New Style Single
13	460073	1	Motor Pan Assembly Single New
14	710182	1	SCR-MC 1/4-20 x 1.00 ZINC
15	711109	4	SCR-ST-B 12 x .50 ZINC
16	711124	1	SCR-ST-B 10 x .37 NI
17	711160	8	SCR Hi/Lo #10 x 5/8 ZINC
18	711161	5	SCR Hi/Lo #10 x 3/4 ZINC
19	711162	2	SCR Hi/Lo #10 x 1 1/2 ZINC
20	711170	1	SCR #10 A Point x 3.5
21	711425	1	Nut-Flanged Wizz 1/4-20
22	711553	2	WSR-Int Lock #10
23	711584	1	WSR #10
24	712320	2	WSR .22 x .45 x .04 Nyl
25	715086	1	Decal, Warning PV to Avoid
26	807051	1	Screen SS 85/105
27	809754	1	Switch Rocker
28	830987	1	Float Assembly
29	833237	1	Strain Relief w/Nut
30	833454	1	Float Cage
***	290085	1	Lid Asy Comp 15G INJ 115
***	290086	1	Lid Asy Comp Molded 230V

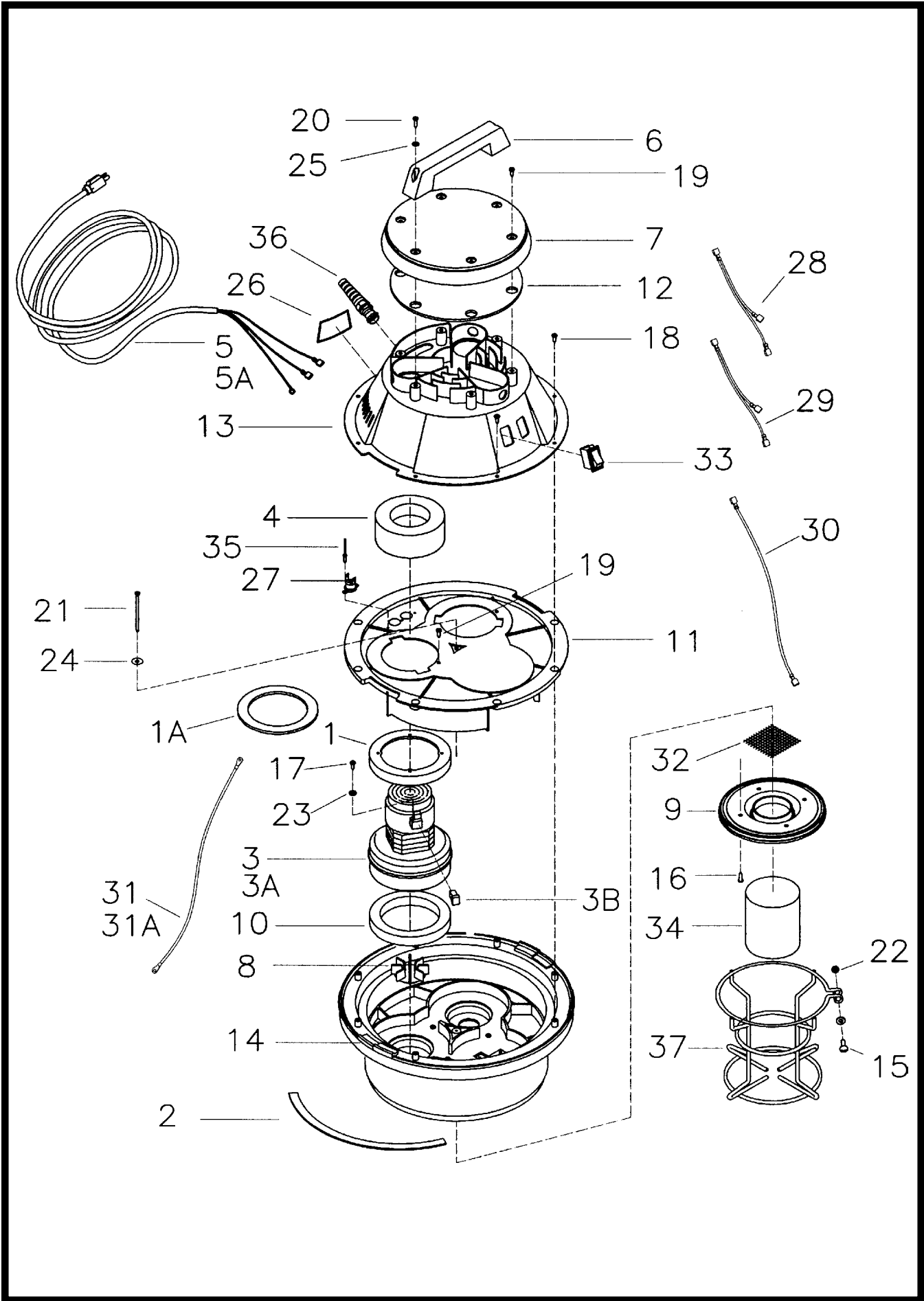

Parts Listings

Item	Part #	Qty	Description
1	290017	2	Molded Vac Moter Gasket
1A	380035	2	Gasket 4.31 x 5.81 x .19 (240V only)
2	290030	1	Lid Gasket Diecut 15G 290
3	380001	2	Vac Motor 6336-00 120V
3A	740149	2	Vac Motor 6296-13 240V
3B	380028	2	Carbon Brush Replacement
4	380064	1	Ring, Foam
5	381020	1	Cord-16GA-3 50FT Med Grey
5A	740600	1	Cord-European F3 G1.5MM Soft B
6	460000	1	Handle 460 Lid Black
7	460003	1	Lid Cover 460 Black
8	460009	2	Valve Vacuum 460 Black
9	460011	1	Float Cage Adaptor 460 Black
10	460019	2	Gasket 3.75 x 5.75 x .75
11	460041	1	Motor Holdown 5.7 x 1
12	460045	1	Dome Seal Gasket 290
13	460071	1	Motor Cover New Style Twin
14	460074	1	Motor Pan Assembly Twin New
15	710182	1	SCR-MC 1/4-20 x 1.00 ZINC
16	711109	4	SCR-ST-B 12 x .50 ZINC
17	711124	4	SCR-ST-B 10 x .37 NI
18	711160	11	SCR Hi/Lo #10 x 5/8 ZINC
19	711161	8	SCR Hi/Lo #10 x 3/4 ZINC
20	711162	2	SCR Hi/Lo #10 x 1 1/2 ZINC
21	711170	1	SCR #10 A Point x 3.5
22	711425	1	Nut-Flanged Wizz 1/4-20
23	711553	2	WSR-Int Lock #10
24	711584	1	WSR #10
25	712320	2	WSR .22 x .45 x .04 Nyl
26	715086	1	Decal, Warning PV to Avoid
27	740250	2	Thermosdisc-290Twin
28	740430	1	Wire Asy
29	740431	1	Wire Asy
30	740529	2	Wire Asy 16G Brown 13.00"
31	750002	1	Ground Wire Asy Yellow (115V)
31A	740116	1	Wire Asy 16G Grn/Yel 14.50" (230V)
32	807051	1	Screen SS 85/105
33	809754	2	Switch Rocker
34	830999	1	Float Asy 3BLT
35	832241	3	Rivet-Pop
36	833237	1	Strain Relief w/Nut
37	833454	1	Float Cage
***	290285	1	Lid Asy Twin 85 INJ 115
***	290286	1	Lid Asy Comp Molded 230V

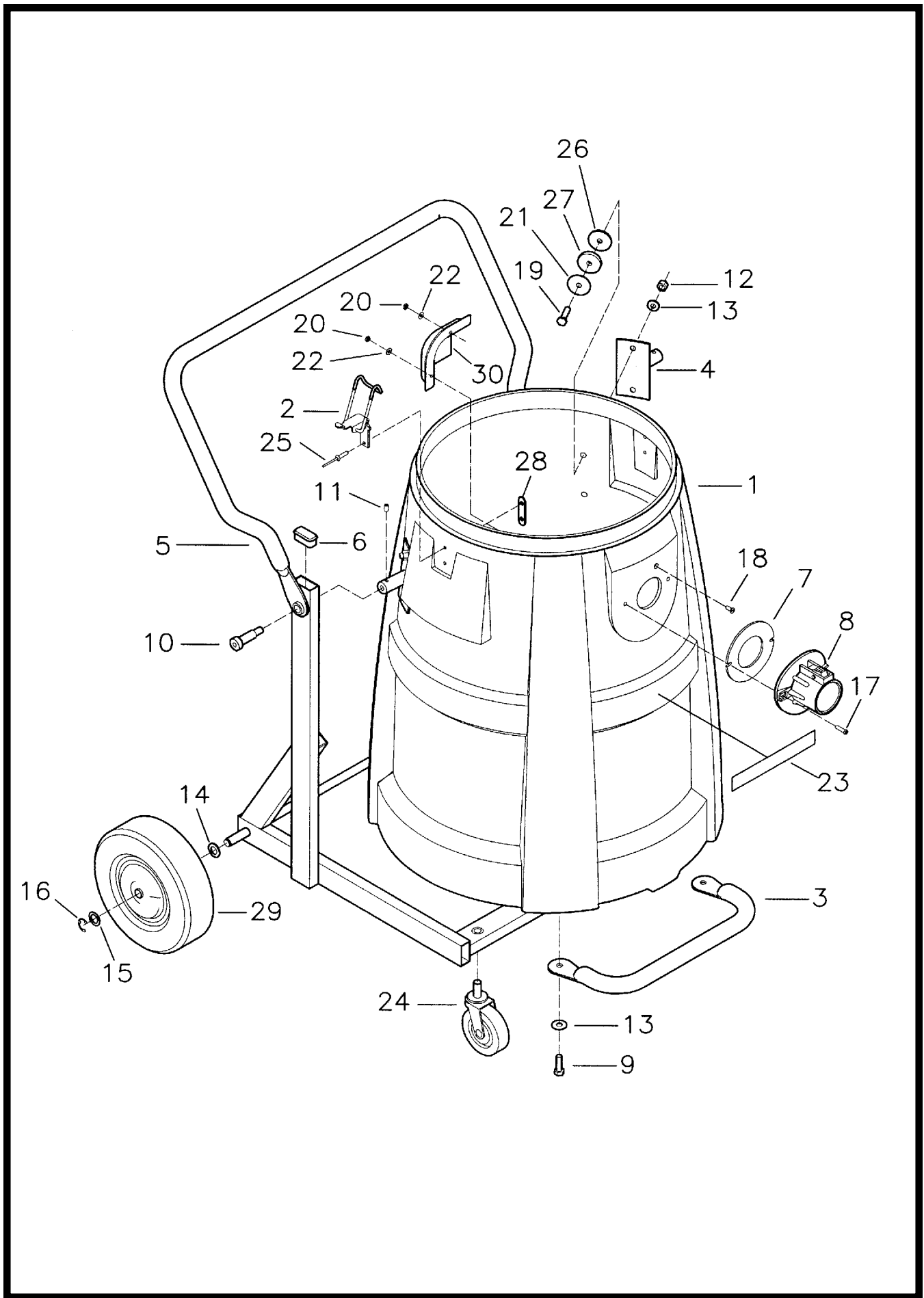

Parts Listings

Item	Part #	Qty	Description
1	390028	1	Tank 20 Gal. T/P
2	390035	2	Latch 390 Series Coated
3	390069	1	Tank Handle
4	390076	2	Tank Mtg. Plate Asy
5	390080	1	Frame Weldment T/P
6	390084	8	Plastic End Cap
7	390087	1	Gasket Diecut
8	390110	1	Intake Assembly Aluminum
9	710196	2	SCR-MC 5/16-18 x .62
10	710992	2	Blt-Shoulder 1/2 x 1.25 x 3/8
11	711005	2	SK 1/4-24 x .31
12	711374	4	Nut - Nyloc 5/16 - 18
13	711506	6	WSR-Flt 5/16 (Narrow) ST PL
14	711524	2	WSR-Wave .52 x .87 x .01
15	711594	2	WSR-Flat .56 x .88 x .03 Nickel
16	711713	2	Ret Ring - E Ext .50
17	712532	2	SCR-MC 10 - 24 x 1.00 SS
18	712544	1	SCR-MC FL HD 10 - 24 x 3/4 SS
19	712576	4	SCR-MC 5/16 - 18 x 1.25 SS
20	712638	3	Nut Hex 10/24 SS Nyloc
21	712759	4	WSR - Flat .31 x 1.37 x .06 SS
22	712764	3	WSR #10 SS
23	715383	1	Decal, MMAN 1 x 6.88 Lt Gry
24	804457	2	Caster 3" Black Hub/Grey Tire
25	828894	4	Rivet-Pop Bapktr-69
26	828980	4	Gasket
27	833756	4	Washer PE
28	833831	2	Clamp Back Plate
29	900008	2	8.00 Dia Wheel
30	900035	1	Defector, Intake

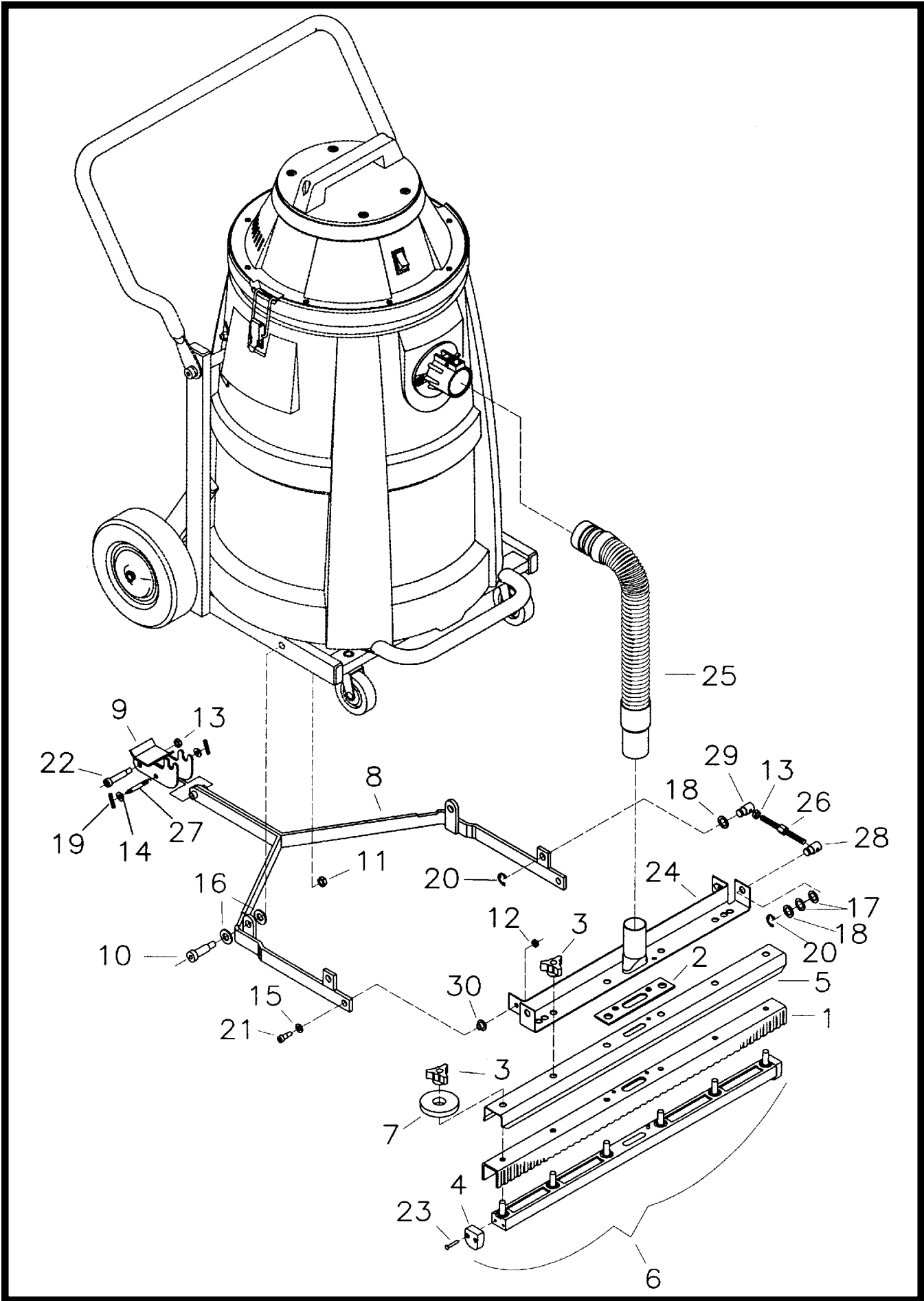

Parts Listings

ITEM	PART	QTY	DESCRIPTION
1	11-145	1	Squeegee Gum Rubber
2	430073	1	Gasket Diecut PS Back
3	430074	6	Adjusting Nut 17B/E
4	430076	2	Nylon Squeegee Insert
5	430078	1	U Profile
6	430079	1	Casting Squeegee Asy
7	430085	2	Squeegee Bumper Wheel
8	470105	1	Squeegee Arm Weldment
9	470106	1	Foot Pedal Tip/Pour
10	710992	2	BLT-Shoulder 1/2 x 1.25 x 3/8
11	711375	2	Nut-Nyloc 3/8-16 1/2 Nut
12	711377	2	Nut-Nyloc 1/4-20
13	711420	3	Nut-Hex JAM 5/16-18 STPL
14	711505	2	WSR-Flt 1/4
15	711506	2	WSR-Flt 5/16 (Narrow) STPL
16	711509	4	WSR-Flt 1/2
17	711524	4	WSR-Wave .52 x .87 x .01
18	711594	4	WSR-Flt .56 x .88 x .03 Nickel
19	711643	2	Pin-Roll .187 x 1.12 PLT
20	711713	4	Ret Ring-E Ext .50
21	712041	2	BLT-Shoulder 1/4-20 x .44 x .37
22	712091	1	BLT-Shoulder 3/8 x 1.5
23	712517	4	SCR-MC FL HD 8/32 x 1 SS
24	750139	1	Squeegee Mtg. Bkt. Asy
25	750140-1	1	Vac Hose Asy w/new cuff
26	750689	2	Stud, Adjusting
27	762084	1	Spring-Ext
28	762256PLT	2	Nut Adj. LH Zinc PLT
29	762257PLT	2	Nut Adj. RH Zinc Dicromat
30	829052	2	Bushing-FLG .312 x .437 x .31 NYL

ADJUSTMENTS

Angle of squeegee assembly can be adjusted if needed, by loosening nut 13 and turning item 26. Both sides may need adjusting so that squeegee blade is parallel to floor in down position.

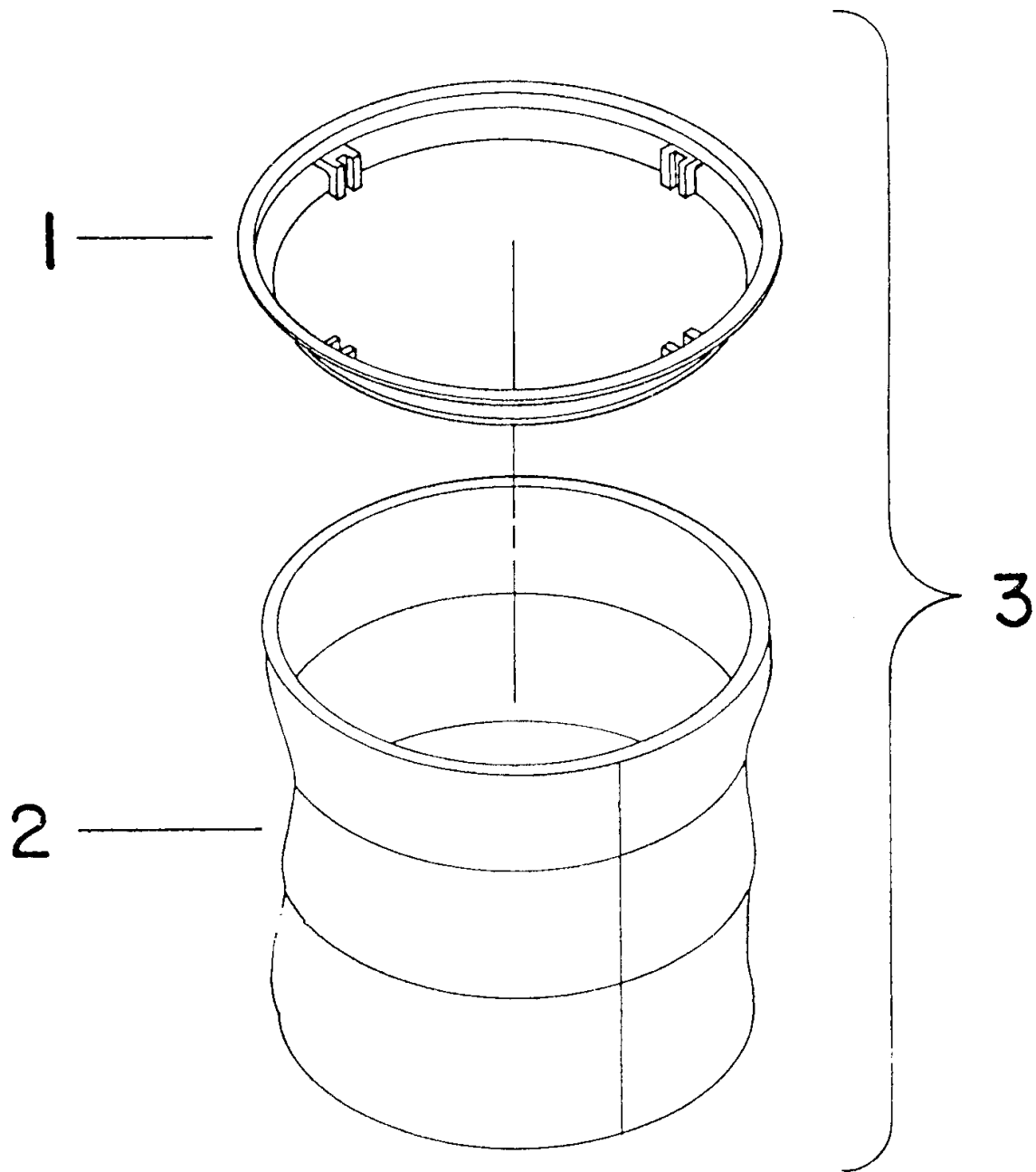

Item	Part #	Qty	Description
1	760131	1	Molded Bag Ring
2	805054	1	Cloth Bag Only
3	805058	XX	Cloth Bag Assy. Complete

LIMITED WARRANTY

Minuteman International, Inc. warrants to the original purchaser/user that this product is free from defects in workmanship and materials under normal use and service for a period of two years from date of purchase. In addition, Minuteman International, Inc. will, at its option, honor labor warranty claims for the first 12 months from date of sale, provided such claims are submitted through and approved by factory authorized repair stations. Minuteman International, Inc. will, at its option, repair or replace without charge, except for transportation costs, parts that fail under normal use and service when operated and maintained in accordance with the applicable operation and instruction manuals.

This warranty does not apply to normal wear, or to items whose life is dependent on their use and care, such as belts, cords, switches, hoses, rubber parts, electrical motor components or adjustments. Parts not manufactured by Minuteman International, Inc. such as engines, batteries, battery chargers, hydraulic pumps, and tires are covered by and subject to the warranties and/or guarantees of their manufacturers. Please contact Minuteman International, Inc. for procedures in warranty claims against these manufacturers.

Special warning to purchaser — Use of replacement filters and/or prefilters not manufactured by Minuteman International, Inc. or its designated licensees, will void all warranties expressed or implied.

A potential health hazard exists without exact original equipment replacement.

All warranted items become the sole property of Minuteman International, Inc. or its original manufacturer, whichever the case may be.

Minuteman International, Inc. disclaims any implied warranty, including the warranty of merchantability and the warranty of fitness for a particular purpose. Minuteman International, Inc. assumes no responsibility for any special, incidental or consequential damages.

This limited warranty is applicable only in the U.S.A. and Canada, and is extended only to the original user/purchaser of this product. Customers outside the U.S.A. and Canada should contact their local distributor for export warranty policies. Minuteman International, Inc. is not responsible for costs or repairs performed by persons other than those specifically authorized by Minuteman International, Inc. This warranty does not apply to damage from transportation, alterations by unauthorized persons, misuse or abuse of the equipment, use of non-compatible chemicals, or damage to property, or loss of income due to malfunctions of the product.

If a difficulty develops with this machine, you should contact the dealer from whom it was purchased.

This warranty gives you specific legal rights, and you may have other rights which vary from state to state. Some states do not allow the exclusion or limitation of special, incidental or consequential damages, or limitations on how long an implied warranty lasts, so the above exclusions and limitations may not apply to you.

Minuteman[®]

World Headquarters
Minuteman International, Inc.
111 South Rohlwing Road
Addison, Illinois 60101

(630) 627-6900
FAX (630) 627-1130

Minuteman Canada, Inc.
2210 Drew Road
Mississauga, Ontario
L5S 1B1

(905) 673-3222
FAX (905) 673-5161

987208
Printed in U.S.A.